

<p>Railing Channel x 25' 2 x 1 x .093/.056 13-63-266 wt/ft: 0.395 Receives .750 picket; Mates with 13-63-227</p> 	<p>2" Railing Channel Cover Plate x 16' 13-63-227 wt/ft: 0.166 Mates with 13-63-266</p> 	<p>Outside Sleeve x 12' 2.252 x 1.280 52-63-4808 (FL) wt/ft: 0.562 Mates with 13-63-266 & 13-63-227</p> 
<p>Railing Channel x 25' 1.50 x 1 x .093/.56 6063-T5 13-63-300 wt/ft: 0.332 Receives .750 picket; Mates with 13-63-305</p> 	<p>1-1/2" Railing Channel Cover Plate x 12' 13-63-305 wt/ft: 0.169 6063-T5 Mates with 13-63-300</p> 	<p>2 x 1 Mid Rail Tube x 24' 52-63-11317 (FL) wt/ft: 0.169</p> 

Railing Channel (with welding legs) 6063-T5

Stock Code	Size in Inches	Approx. Wt/Lin ft.
13-63-264	1-3/4 x 3/4 x .093/.062 x 24' (receives 3/4" picket)	0.330
13-63-261	2 x 7/16 x .093 x 25' 2" (no legs)	0.294
13-63-262	2 x 3/4 x .125/.093 x 23' 10" (no legs)	0.440
13-63-267	2 x 1 x .090/.056 x 25' (receives 1" picket)	0.395 (FL)

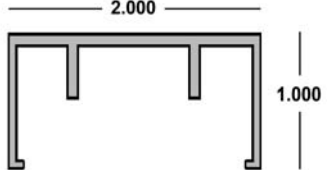
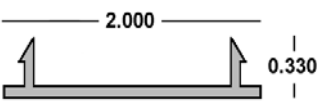
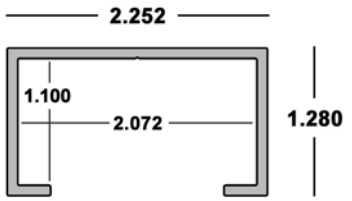
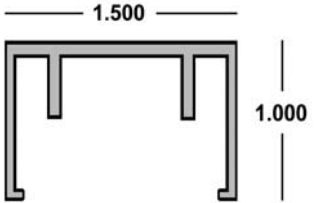
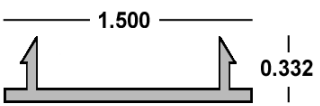
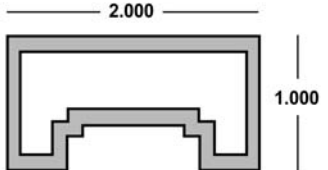
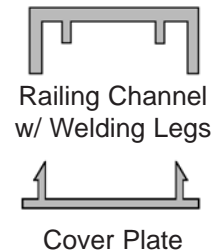

Pre-Punched Railing Channel

Mill Finish 6063-T5 Arch Aluminum Channel - Spacing is inside edge to inside edge

Stock Code	Size in Inches	Picket Size	between Holes
13-63-265P (FL)	2 x 1 x 1/8 x 20'	3/4"	3.75"
13-63-265PS (FL)	2 x 1 x 1/8 x 20'	3/4"	3.50"
13-63-265PP (FL)	2 x 1 x 1/8 x 20'	1"	3.75"
13-63-265PPS (FL)	2 x 1 x 1/8 x 20'	1"	3.25"
13-63-266P (FL)	2 x 1 x .093/.056 x 25' with welding legs	3/4"	3.75"
13-63-266PS (FL)	2 x 1 x .090/.056 x 25' with welding legs	3/4"	3.50"
13-63-267P (FL)	2 x 1 x .090/.056 x 25'	1"	3.75"
13-63-267PS (FL)	2 x 1 x .093/.056 x 25'	1"	3.25"

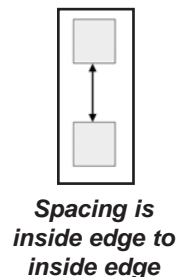

Mill Order Items: Not in Stock - Custom Sizes & Lengths Available
Minimum Order Required

Handrailing 11



Eastern Metal Supply
Quality Shapes In Aluminum

[EMS FL](#)

1-800-432-2204
(561) 588-4780 - fax

[EMS NC](#)

1-800-343-8154
(704) 391-2267 - fax

[EMS TX](#)

1-800-996-6061
(281) 656-2297 - fax

[EMS MO](#)

1-888-822-6061
(314) 344-3349 - fax

Additional Locations: West Palm Beach & Lakeland, FL and Newark, DE

[website: www.easternmetal.com](http://www.easternmetal.com) [e-mail: info@easternmetal.com](mailto:info@easternmetal.com) [version: 03/16/10](#)

**2-1/4" x 3-7/8" Centerline Projected
Pipe Bracket x 16'**

31-63-135 wt/ft: 1.940

163

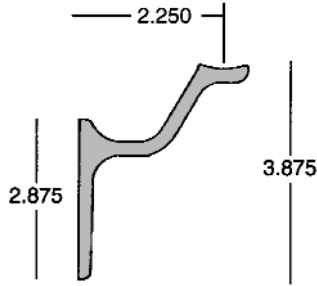

**2-1/2" x 3-7/8" Centerline Projected
Pipe Bracket x 16'**

31-63-120 wt/ft: 2.012

162

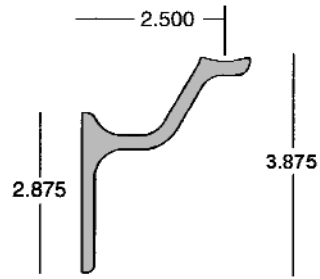

**2-7/8" x 3-1/2" Centerline Projected
Pipe Bracket x 16'**

31-63-105 wt/ft: 1.853

160

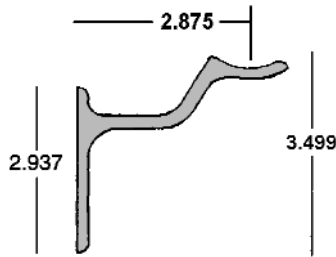

**2-1/2" x 4-3/8" Centerline Projected
Pipe Bracket x 16'**

31-63-140 wt/ft: 2.154

164

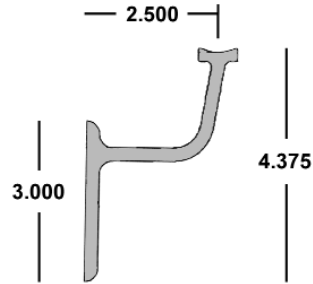

**2-7/8" x 3-7/8" Centerline Projected
Pipe Bracket x 16'**

31-61-145 wt/ft: 2.1815

165

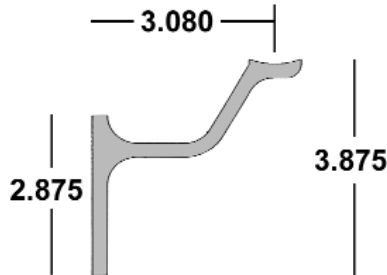

**3.125" x 4.409" Centerline Projected
Pipe Bracket x 12'**

31-61-150 wt/ft: 2.264

Meets NFPA 101
Life Safety Code

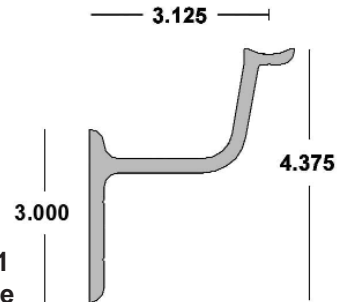

SCH 40 Pipe - T4 Temper (for bending)

Stock Code **Size in Inches**
(Size x OD x ID x Wall)

18-63-231 1-1/4 x 1.660 x 1.380 x .140 x 24'
18-T4-500 1-1/2 x 1.900 x 1.610 x .145 x 24'

Hard-Rok 61-00-007

Quik Rok 61-00-001

Anchoring Cement; Available in 5 Gallon Buckets

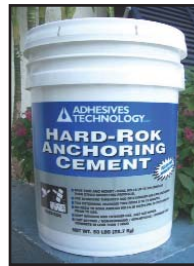

Handrailing 12



Eastern Metal Supply

Quality Shapes In Aluminum

EMS FL

1-800-432-2204

(561) 588-4780 - fax

EMS NC

1-800-343-8154

(704) 391-2267 - fax

EMS TX

1-800-996-6061

(281) 656-2297 - fax

EMS MO

1-888-822-6061

(314) 344-3349 - fax

Additional Locations: West Palm Beach & Lakeland, FL and Newark, DE

website: www.easternmetal.com

e-mail: info@easternmetal.com

version: 09/28/07

Railing Channel *(with welding legs)* 6063-T5

Stock Code

Size in Inches

Approx. Wt/Lin ft.

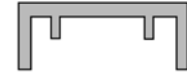

Railing Channel w/ Welding Legs



Cover Plate

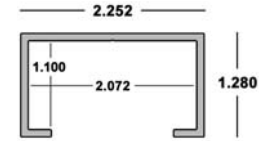

2.252 x 1.280 Outside Sleeve

13-63-300	1-1/2 x 1 x .093/.056 x 25' (receives 3/4" picket)	0.322
13-63-305	1-1/2 x 12' Channel Cover Plate	0.169
13-63-264	1-3/4 x 3/4 x .093/.062 x 24' (receives 3/4" picket)	0.330
13-63-261	2 x 7/16 x .093 x 25' 2" (no legs)	0.294
13-63-262	2 x 3/4 x .125/.093 x 23' 10" (no legs)	0.440
13-63-266	2 x 1 x .093/.056 x 25' (receives 3/4" picket)	0.395
13-63-267	2 x 1 x .090/.056 x 25' (receives 1" picket)	0.395 (FL)
13-63-227	2 x 16' Channel Cover Plate	0.166
52-63-4808*	2.252 x 1.280 Outside Sleeve x 12' (*mates with 13-63-266, 13-63-267)	0.562 (FL)

Pre-Punched Railing Channel

Mill Finish 6063-T5 Arch Aluminum Channel

Spacing is inside edge to inside edge

Stock Code	Size in Inches	Picket Size	between Holes
13-63-265P (FL)	2 x 1 x 1/8 x 20'	3/4"	3.75"
13-63-265PS (FL)	2 x 1 x 1/8 x 20'	3/4"	3.50"
13-63-265PP (FL)	2 x 1 x 1/8 x 20'	1"	3.75"
13-63-265PPS (FL)	2 x 1 x 1/8 x 20'	1"	3.25"
13-63-266P (FL)	2 x 1 x .093/.056 x 25' with welding legs	3/4"	3.75"
13-63-266PS (FL)	2 x 1 x .090/.056 x 25' with welding legs	3/4"	3.50"
13-63-267P (FL)	2 x 1 x .090/.056 x 25'	1"	3.75"
13-63-267PS (FL)	2 x 1 x .093/.056 x 25'	1"	3.25"

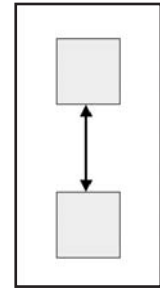
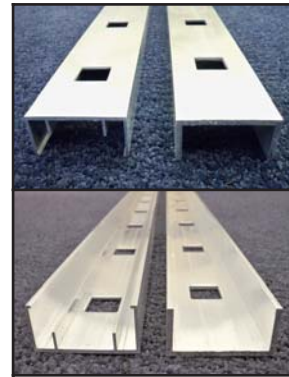

Spacing is inside edge to inside edge

Pre-Punched Railing Channel

Mill Order Items: Not in Stock - Custom Sizes & Lengths Available - Minimum Order Required

Standards 14



Eastern Metal Supply
Quality Shapes In Aluminum

[EMS FL](#)

1-800-432-2204
(561) 588-4780 - fax

[EMS NC](#)

1-800-343-8154
(704) 391-2267 - fax

[EMS TX](#)

1-800-996-6061
(281) 656-2297 - fax

[EMS MO](#)

1-888-822-6061
(314) 344-3349 - fax

Additional Locations: West Palm Beach & Lakeland, FL and Newark, DE

website: www.easternmetal.com

e-mail: info@easternmetal.com

version: 07/31/09