

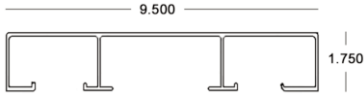
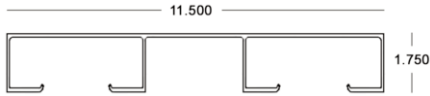
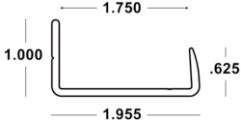
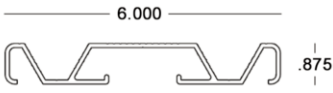
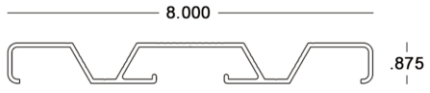

BLEACHER SHAPES

<p>9.5" Bleacher Plank B-1 <u>52-63-7632</u> x 21' <u>52-63-5888</u> x 30' wt/ft: 1.932 6063 T6 M/F</p> 	<p>11.5" Bleacher Plank B-2 <u>52-63-4283</u> x 16' <u>52-63-6118</u> x 20' <u>52-63-13304</u> x 24' <u>52-63-13658</u> x 32' wt/ft: 2.13 6063 T6 M/F</p> 	<p>Bleacher Plank End Cap x 12' <u>52-63-6786</u> 6063-T6 Mill Finish</p> 
<p>6" Toe Kick Board x 30' <u>52-63-5892</u> wt/ft: 1.082 6063 T6 M/F</p> 	<p>8" Toe Kick Board MILL ORDER <u>52-63-13576</u> wt/ft: 1.274</p> 	<p>2 x 1.25 Slotted Bleacher Clip BLEACHER-CLIP 500 pc box For 9.5" Bleacher Plank 6063-T6 Mill Finish</p> 

SEAWALL CAPS & SLEEVES

<p>7" Bulkhead Cap x 20' <u>52-61-2780</u> (Serrated Top) 6005-T5</p> 	<p>7" Bulkhead Sleeve x 2' <u>52-61-2781</u> 6005-T5 *90° Corners available upon request</p> 
<p>8" Bulkhead Cap x 20' <u>30-61-210</u> (Serrated Top) 6005-T5</p> 	<p>8" Bulkhead Sleeve x 2' <u>30-61-215*</u> 6005-T5 *90° Corners available upon request</p> 
<p>Seawall Footer x 15' <u>52-61-3392</u> Self Mating; 6061-T6</p> 	

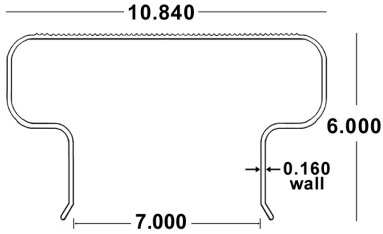
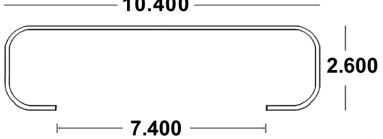
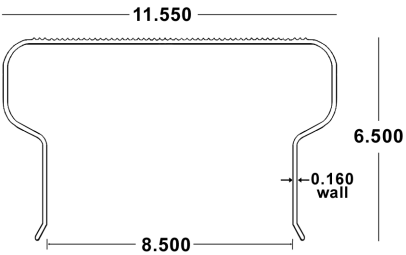
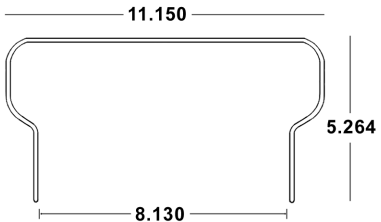
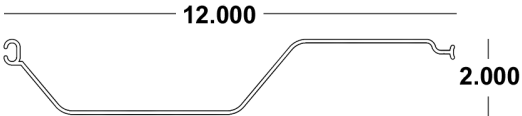
Dock 08



Eastern Metal Supply
 Quality Shapes In Aluminum

EMS FL

1-800-432-2204
 (561) 588-4780 - fax

EMS NC

1-800-343-8154
 (704) 391-2267 - fax

EMS TX

1-800-996-6061
 (281) 656-2297 - fax

EMS MO

1-888-822-6061
 (314) 344-3349 - fax

Additional Locations: West Palm Beach & Lakeland, FL; Newark, DE; Akron, OH, Van Buren, AR; Atlanta, GA and Dallas, TX

website: www.EasternMetal.com

e-mail: info@EasternMetal.com

version: 02/27/19